



Outillage nécessaire (non fourni)



Pose des contre-coulisses

Store avec coffre

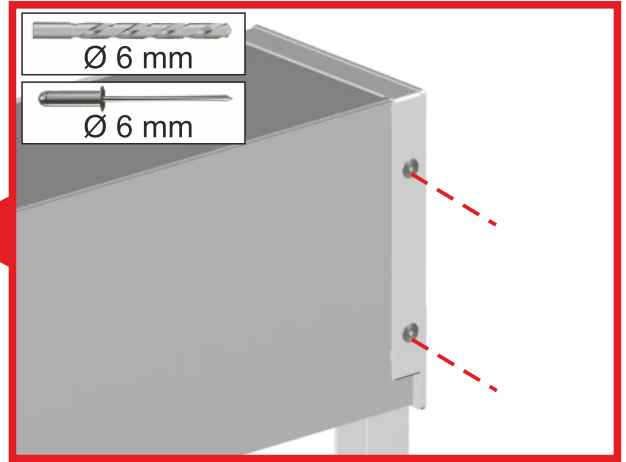
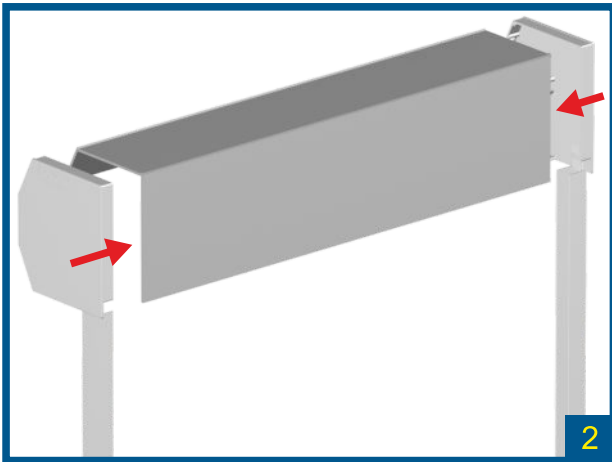
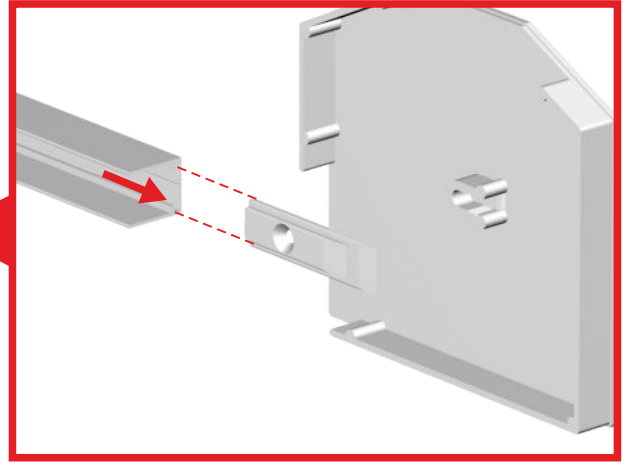
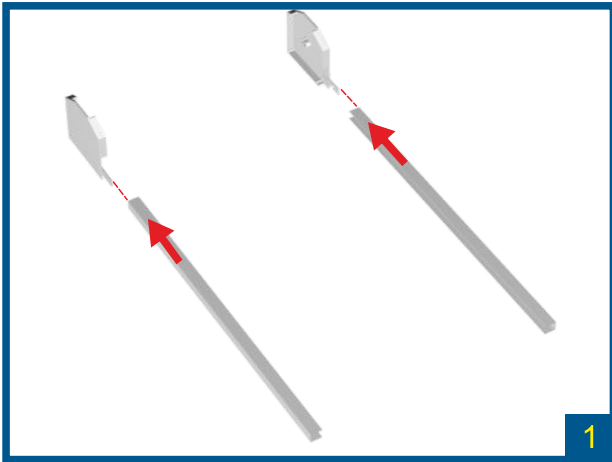

Store sans coffre

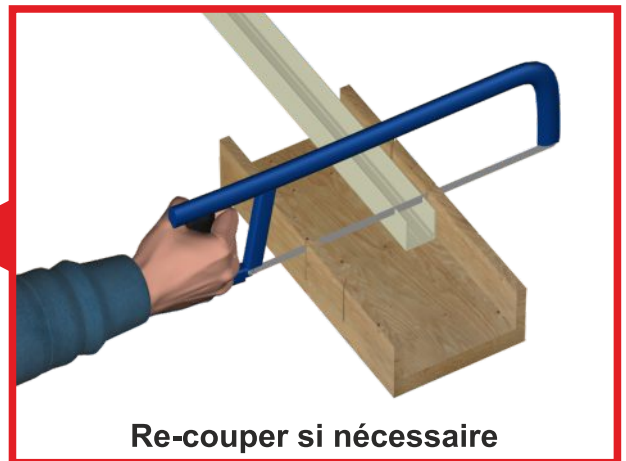
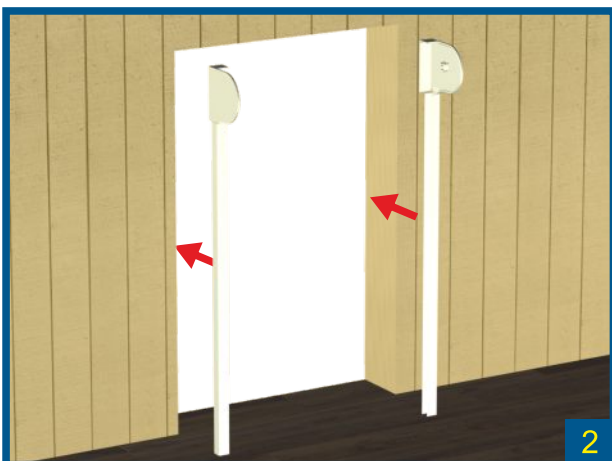
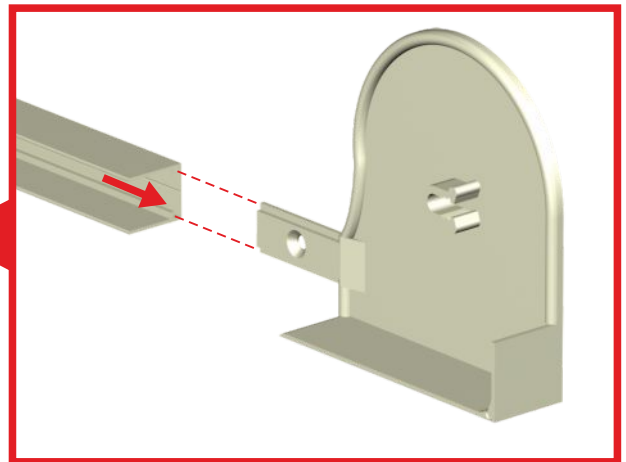
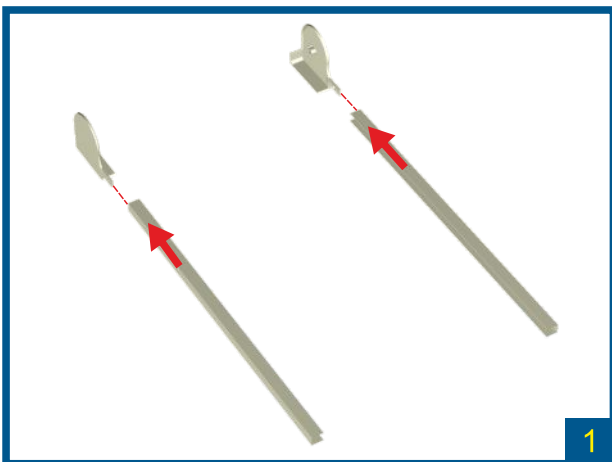

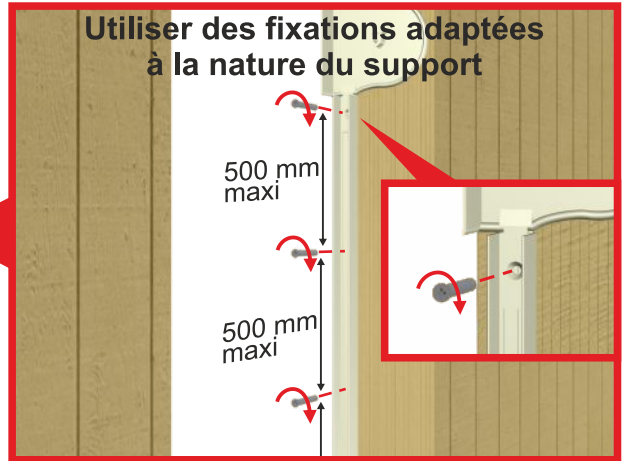
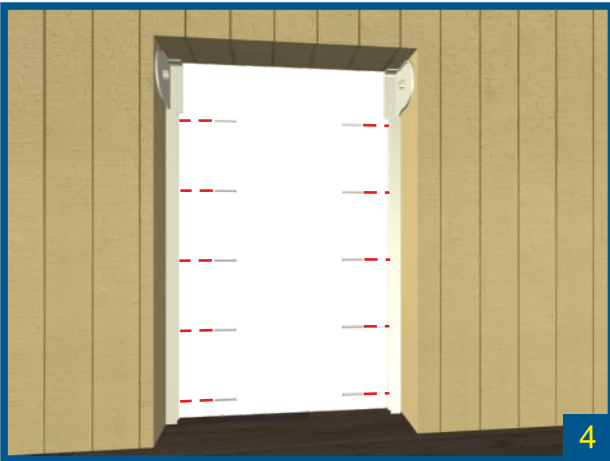
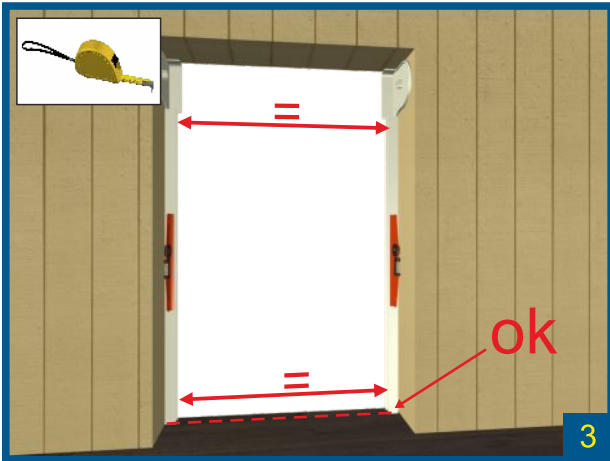

Pose du tube d'enroulement

L < 3,5m

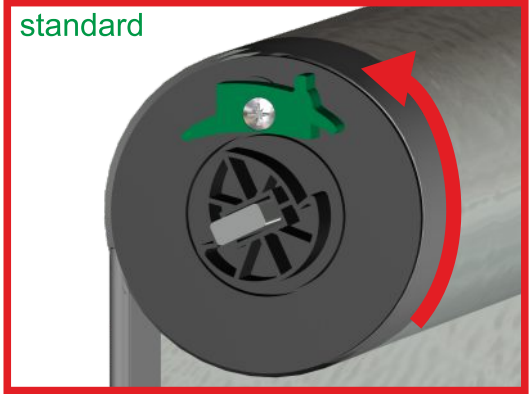

standard

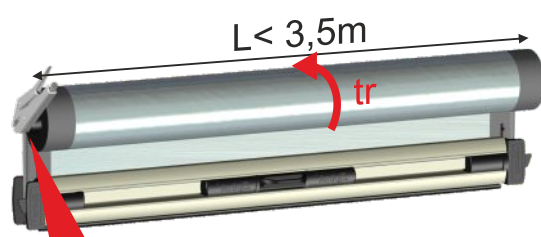

$L < 3,5m$
 tr



$tr = 10 \times L$ (mètre)



1a

L > 3,5m

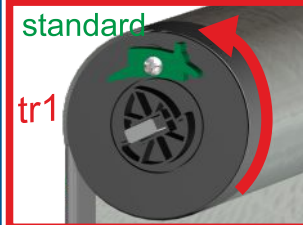

standard
 $tr1$

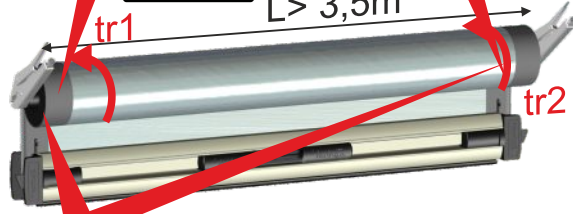

HELPER
 $tr2$

$L > 3,5m$
 $tr1$ $tr2$



$tr1 + tr2 = 10 \times L$
 $tr1 \text{ max} = 35$
 $tr2 \text{ max} = 25$

Exemples :
 1) $L = 3500$ $tr1 = 25$ $tr2 = 10$
 2) $L = 4500$ $tr1 = 30$ $tr2 = 15$

1b

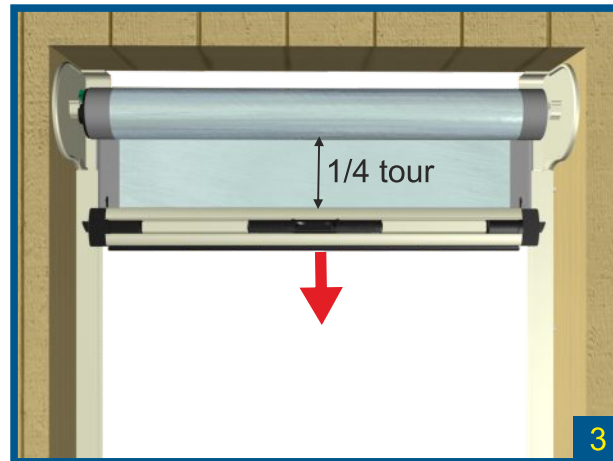
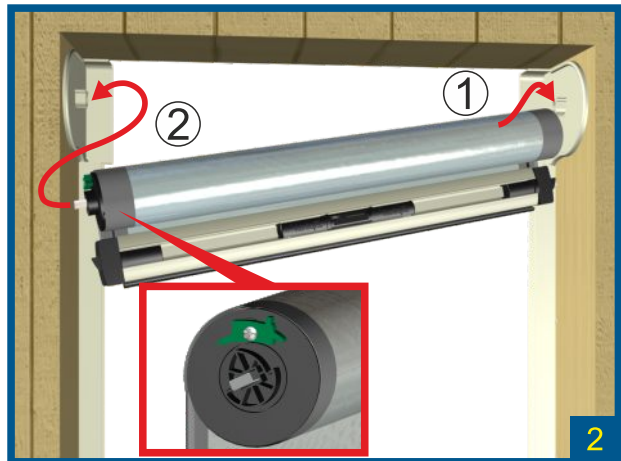

Pose des coulisses

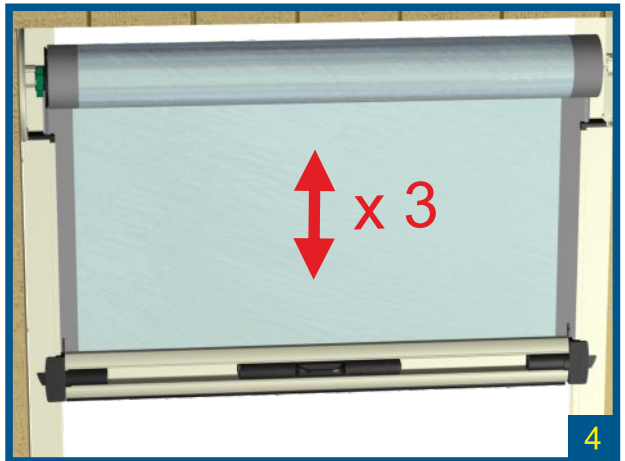
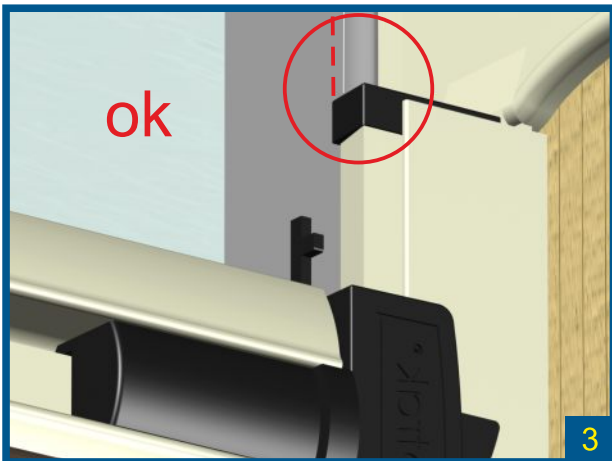
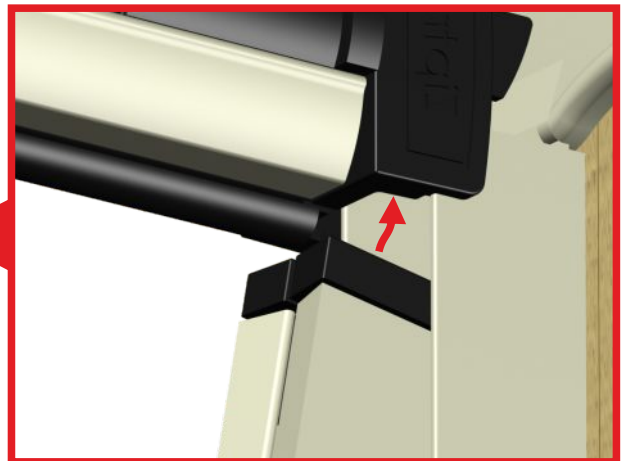
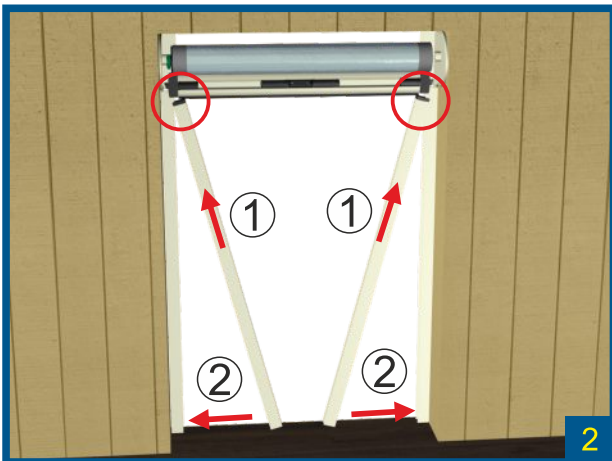
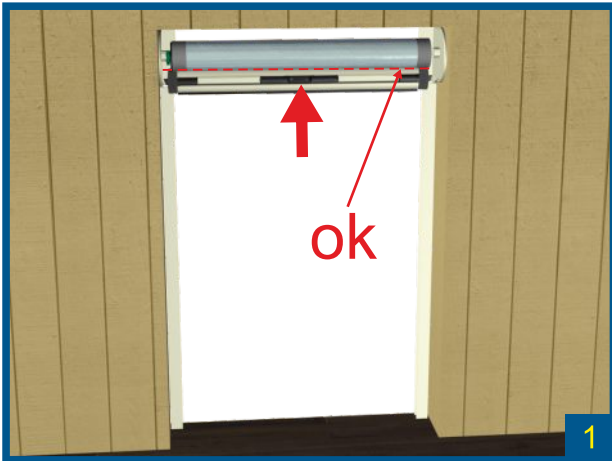

Pose des coulisses

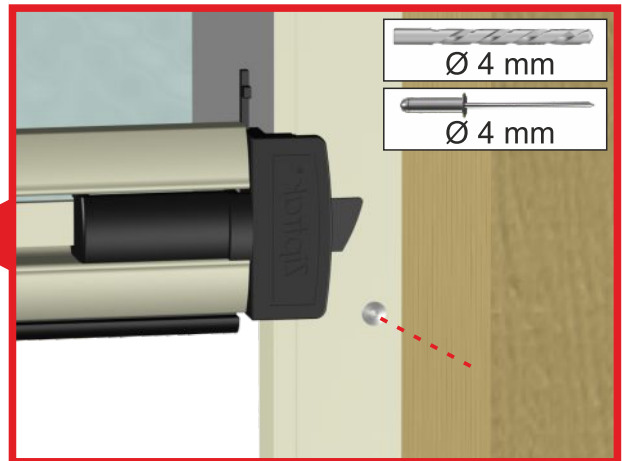
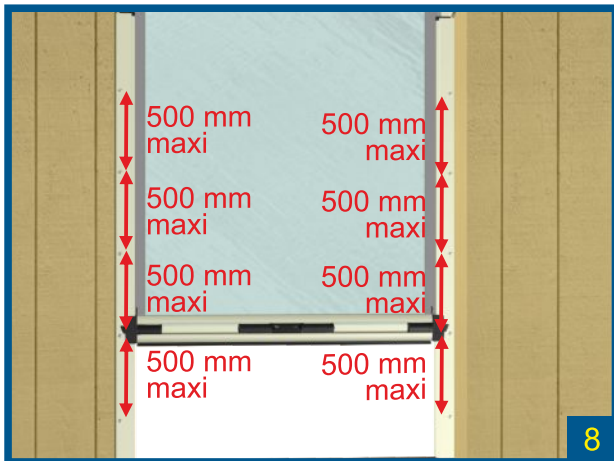
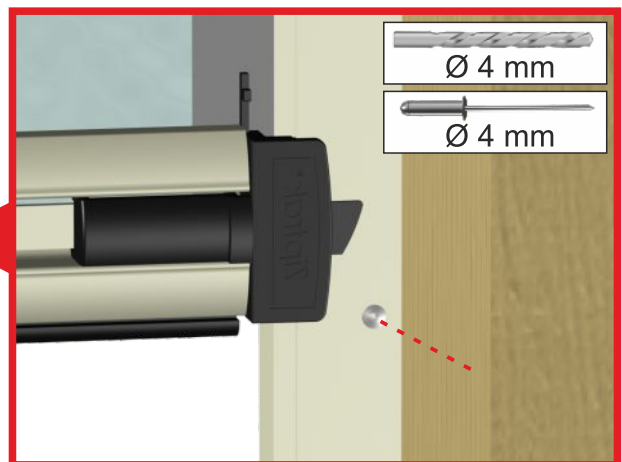
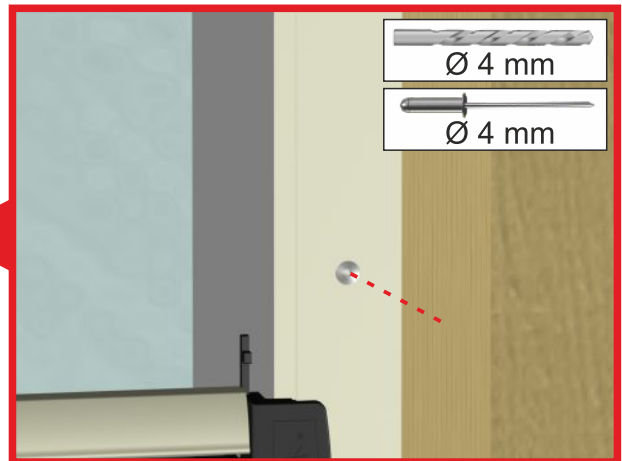

Pose des pinces toile et butées hautes

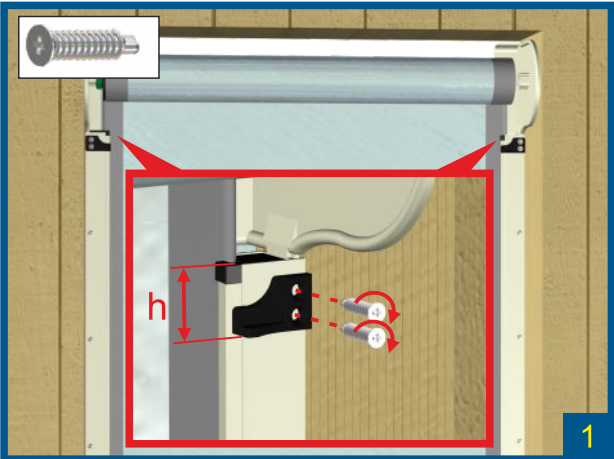
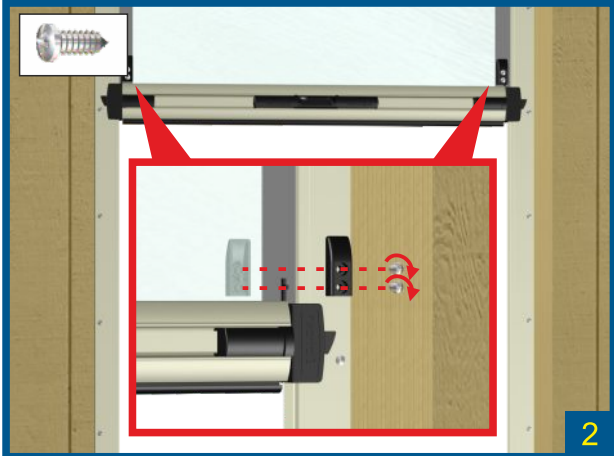
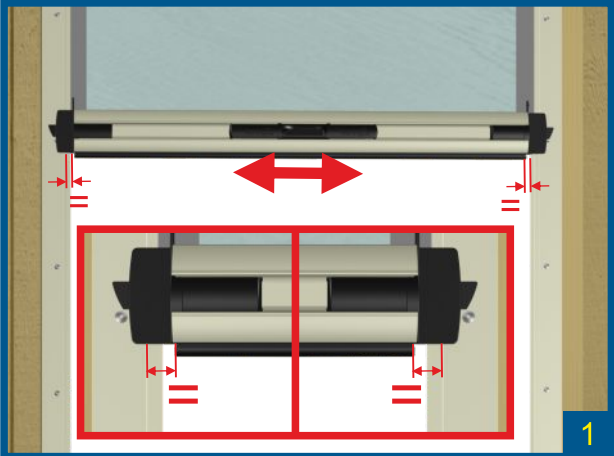

Ajustement de la tension du ressort

Augmentation de la tension du ressort

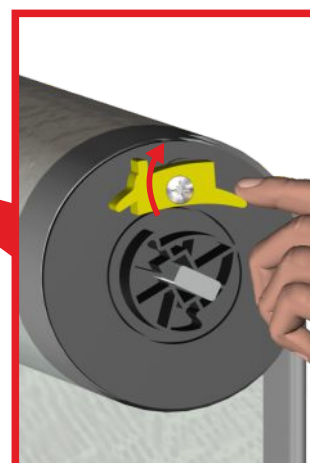
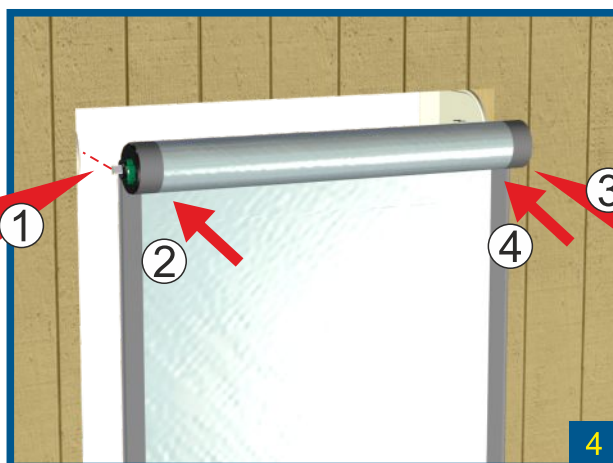
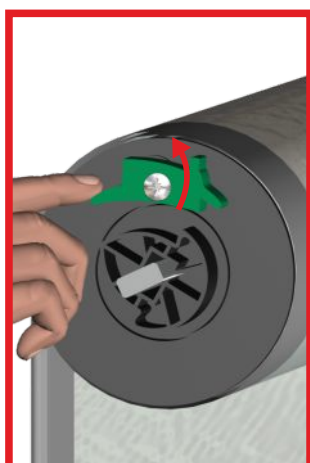
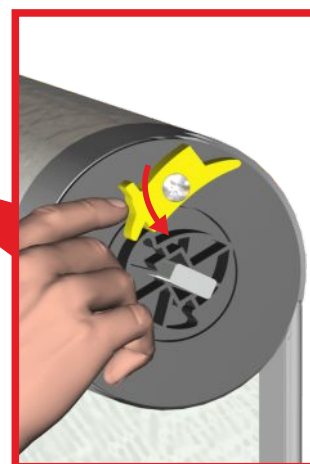
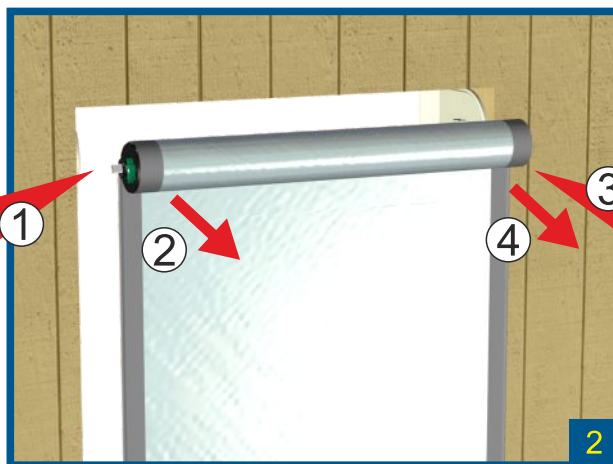
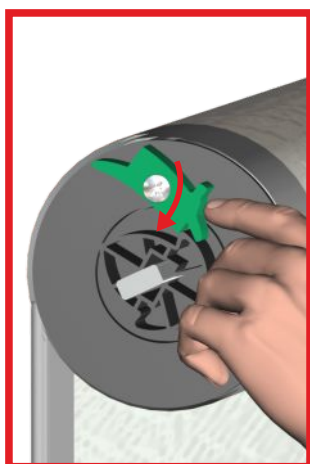

Ajustement de la tension du ressort

Diminution de la tension du ressort

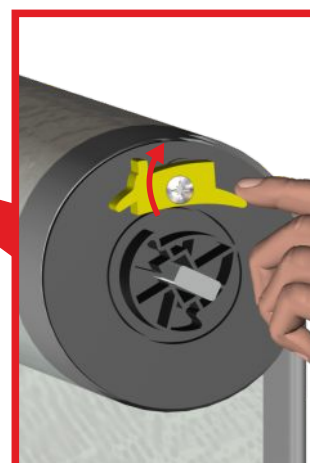
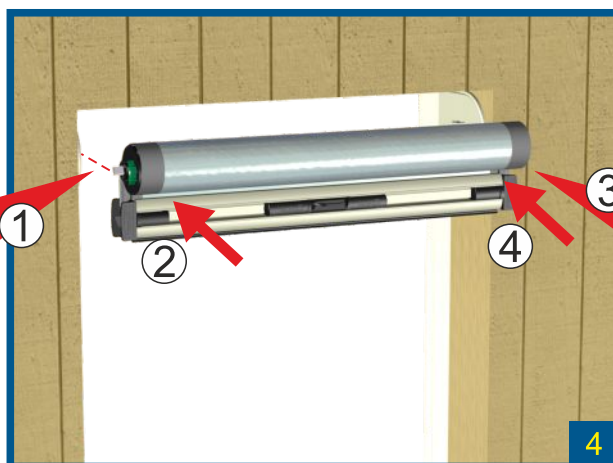
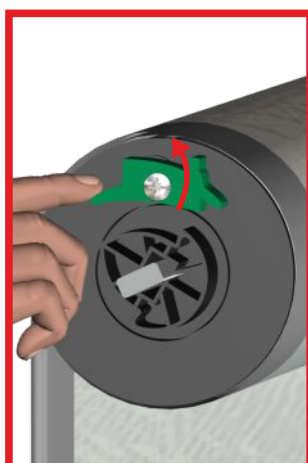
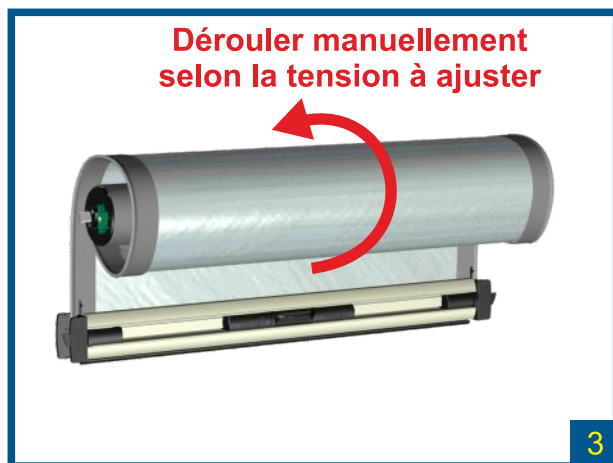
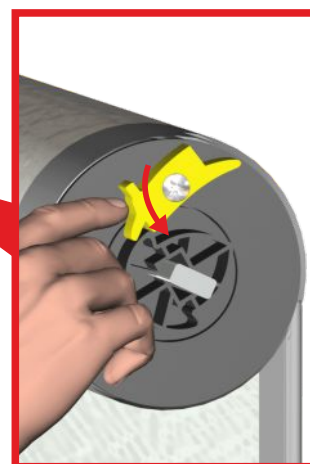
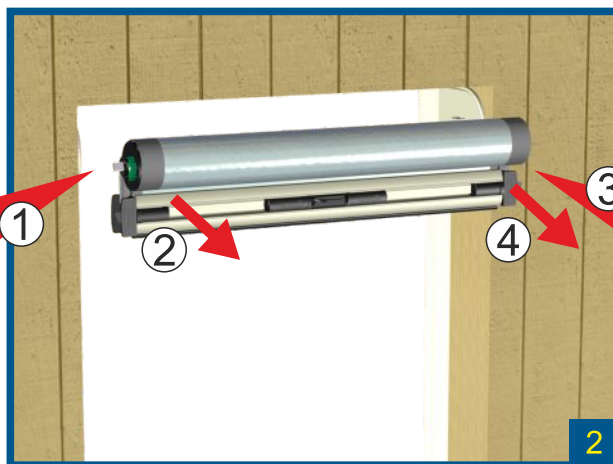
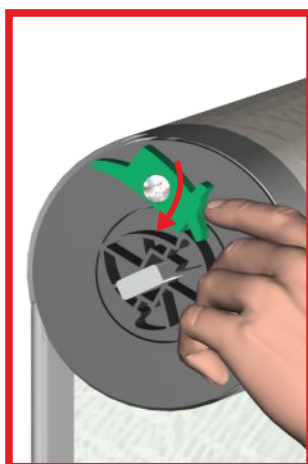
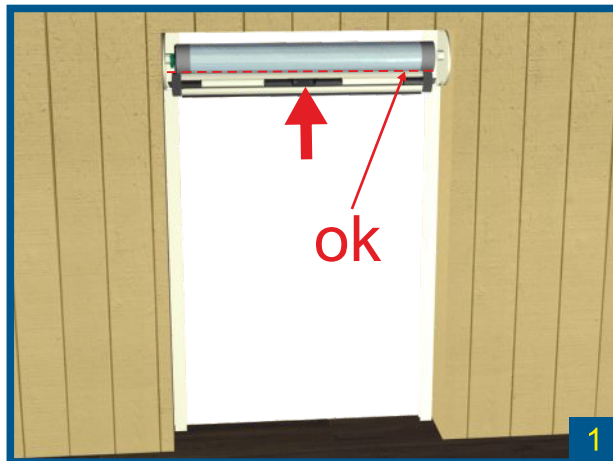

Pose des butées de verrouillage

Pour une pose en baie

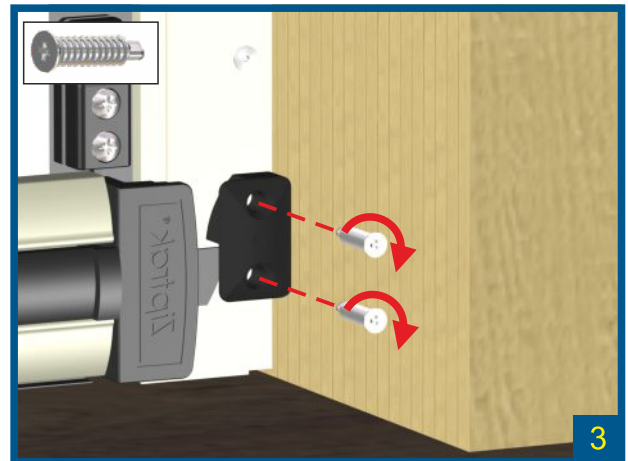
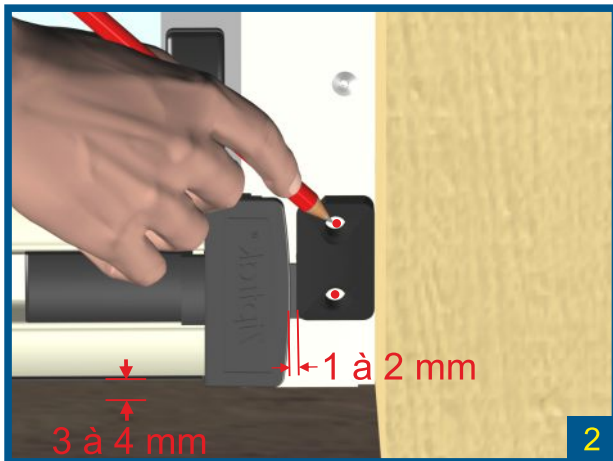
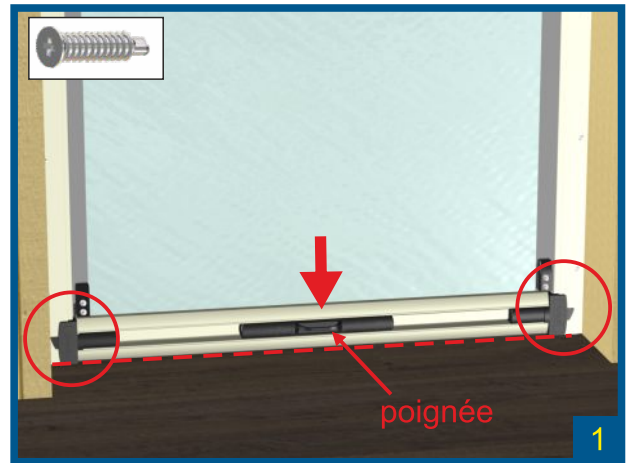

Pour une pose en façade intérieure, poignée intérieure

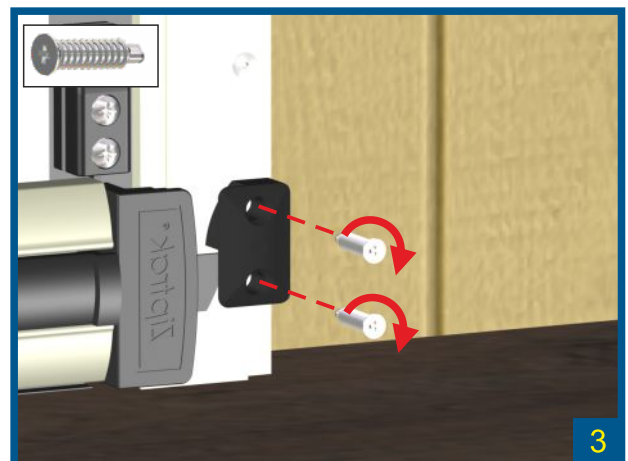
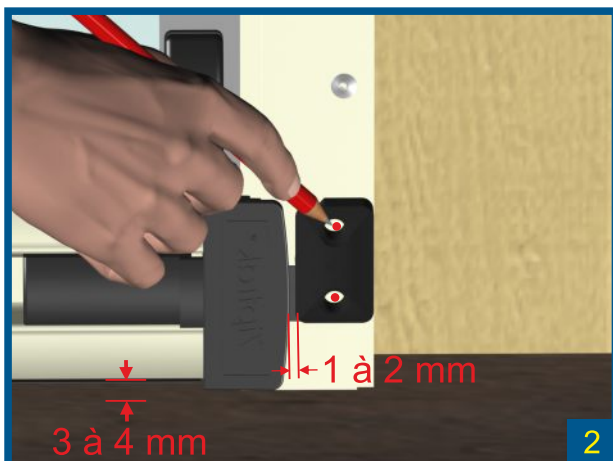
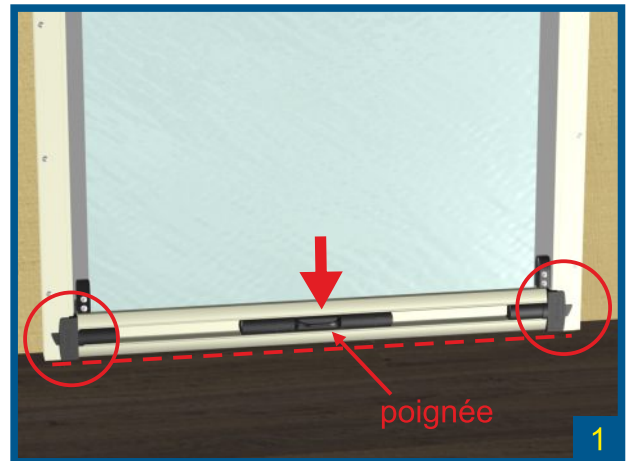

Pour une pose en façade extérieure, poignée intérieure

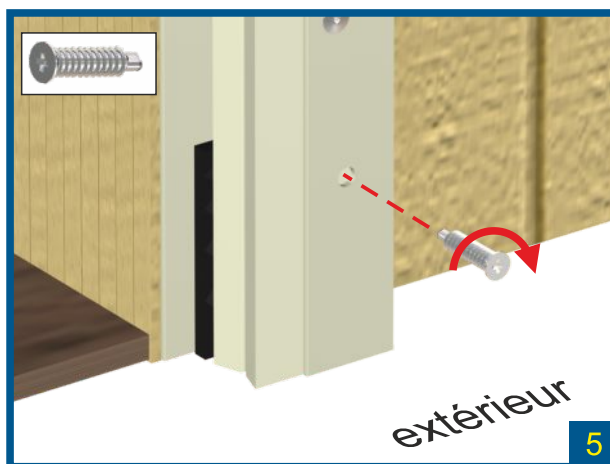
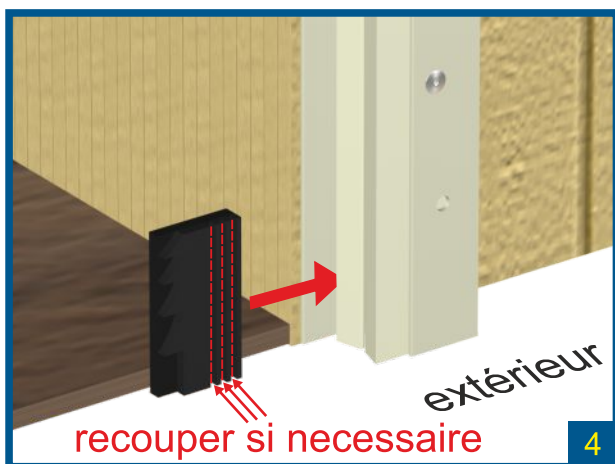
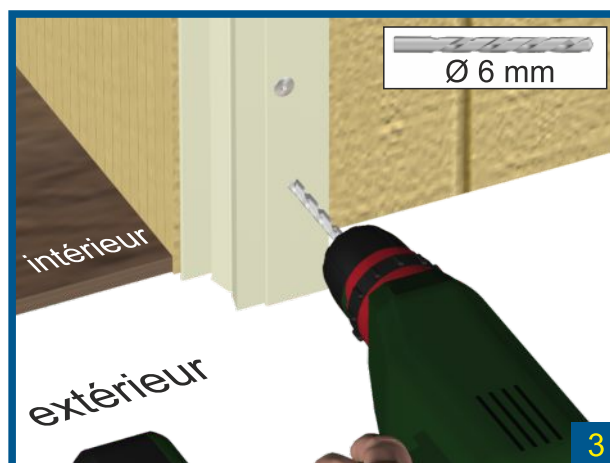
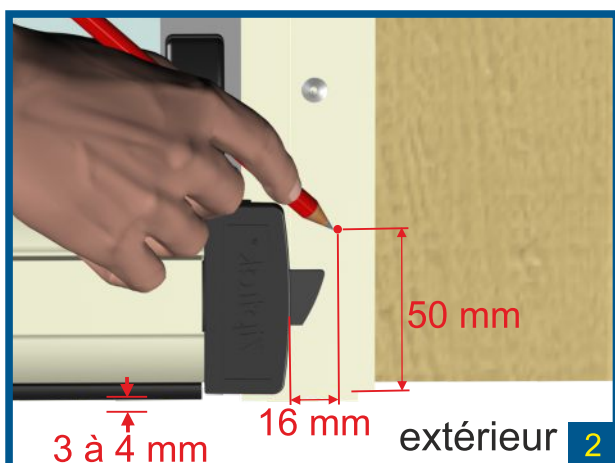
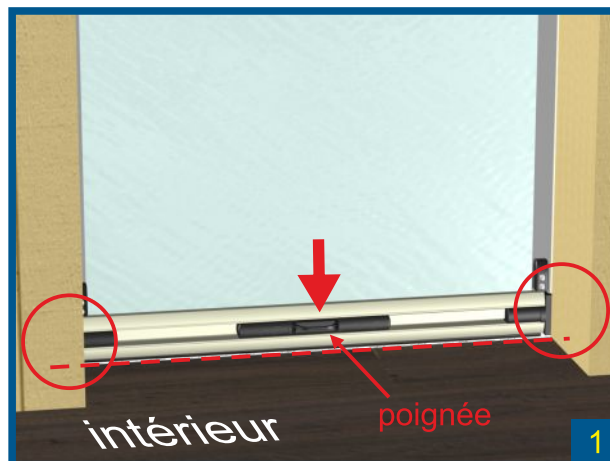

Entretien, garantie

Les conseils simples qui suivent, faciliteront l'utilisation et la préservation de vos stores Ziptrak® durant de nombreuses années.

Fonctionnement de vos stores Ziptrak®

Manœuvrez vos stores Ziptrak® à partir du centre de la barre de charge, pour obtenir un mouvement régulier de la bâche du store, sur le tube d'enroulement.

Dans des conditions venteuses (vent de 30 km/h ou plus), les stores Ziptrak® doivent être positionnés :

- soit complètement fermés jusqu'au bas et verrouillés dans cette position
- soit complètement rétractés (ouverts jusqu'en haut).

Dans des conditions fortement venteuses, il est possible qu'il soit difficile de manœuvrer les stores Ziptrak à cause de la pression du vent sur la bâche. Par conséquent, il est préférable d'attendre une pause du vent avant de manœuvrer les stores. Ou bien vous pouvez faire pression avec la main contre le vent sur la bâche du store, de façon à le libérer d'entre les coulisses Ziptrak. Ensuite vous pourrez manœuvrer le store.

De la même façon, le Ziptrak peut être difficile à manipuler par temps froid. Il est nécessaire d'insister pour ouvrir le Ziptrak lors de la première manœuvre.

Maintenance de vos stores Ziptrak®

Lavez la surface de vos stores Ziptrak® régulièrement avec un tissu très doux, et de l'alcool ménager. Les détergents et produits abrasifs sont déconseillés au risque de rayer, opacifier ou jaunir la toile. Lorsque vous nettoyez des stores en PVC teinté ou transparent, assurez-vous que votre chiffon est très doux et ne comporte pas de points durs, car ce type de tissu aura tendance à rayer facilement la surface.

De façon générale les stores Ziptrak® ne doivent pas être lubrifiés. Cependant, dans un environnement poussiéreux, on peut utiliser un spray silicone de qualité alimentaire. Pour appliquer le lubrifiant, descendez vos stores Ziptrak® jusqu'en bas, appliquez le spray silicone dans la gorge entre le jonc à double ailettes et la coulisse Ziptrak®, des deux côtés de la bâche.

- IL EST TRÈS IMPORTANT DE NE PAS UTILISER DE LUBRIFIANT PÉTROLIER COMME DU WD40 OU AUTRE PRODUIT SIMILAIRE, CAR ILS ENDOMMAGENT LE JONC ET ACCUMULENT LA POUSSIÈRE DANS LA COULISSE DU ZIPTRAK.**

Les stores étant enroulés pour le transport, il faudra laisser le store fermé quelques jours pour que la toile retrouve sa forme.

Utilisation de la perche de secours

La perche de manœuvre utilisée pour les grandes hauteurs doit venir attraper la barre de charge et non la poignée de verrouillage pour une bonne manipulation.

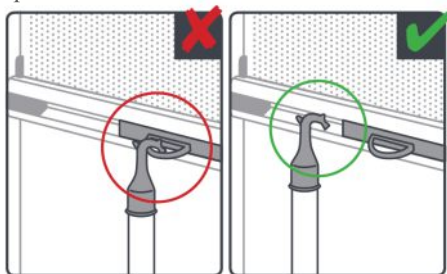

Remontée du store

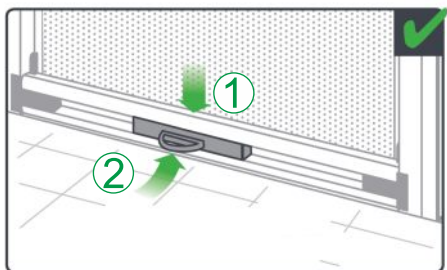

Manipulation du store

Toujours manipuler le store au centre de la barre de charge et non sur un côté.

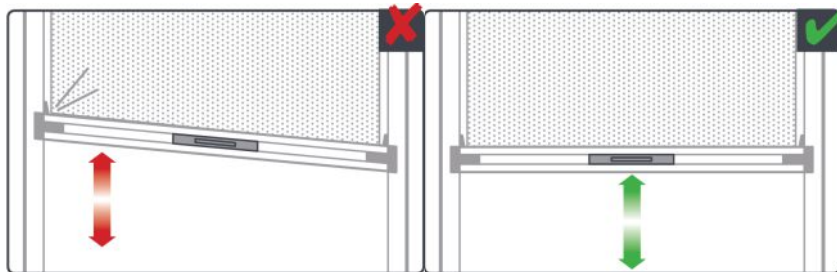

Exposition à la pluie

Laisser sécher le store en position fermée afin d'éviter toute moisissure

